

ALCR-36N

APE-562/2036



Replacement control unit installation manual for 230 VAC operators, with 433 MHz receiver



ABEXO è un marchio registrato di proprietà
di ABTECNO srl - Via Cicogna 95
40068 San Lazzaro di Savena (BO)
info@abtecno.com www.abexo.tech

WARNINGS FOR THE INSTALLER - GENERAL SAFETY INSTRUCTIONS

1. Before installing this equipment, read the instructions carefully.
2. These instructions should be kept for future reference until the equipment is installed and operational.
3. This product has been designed and manufactured for the use described in these instructions. Any other use could damage the equipment and be a source of danger, even serious danger, to the safety of users and the installer.
4. All packaging materials must be kept out of the reach of children as they are a source of danger.
5. The manufacturer declines all responsibility for damage caused by improper use of this equipment.
6. The manufacturer is not responsible for non-compliance with EC or other standards that must be observed when installing this product in a machine.
7. Do not install this equipment in an explosive atmosphere, as the presence of gas or fumes is dangerous.
8. Installation must be carried out by qualified personnel in compliance with the law.
9. Before performing any operation on the equipment, the main power supply must be disconnected.
10. An omnipolar switch with a contact opening distance equal to or greater than 3 mm should be installed on the automation power supply.
We recommend using a 6A circuit breaker with omnipolar interruption.
11. We recommend installing at least one flashing light and appropriate warning signs.
12. During the movement of the automation system, children, people, or animals must not be present near the moving doors.
13. Vehicles must only be allowed to pass when the automation system is completely open, stationary, and paused.
14. In the event of a malfunction, the user must refrain from any attempt at repair or technical intervention and immediately call a professional technical assistance service.
15. The product must not be used by children or persons with reduced physical, sensory, or mental capabilities, or lack of experience and knowledge, unless they have been properly instructed. Do not access the card for adjustments and/or maintenance.
16. The grounding system must be properly installed and all equipment in the system must be connected to it.
17. Anything not described in the instructions is not permitted.

GENERAL DESCRIPTION

The **ALCR-36N** control unit can control 1 or 2 hydraulic/electromechanical operators at 230V. Condominium and residential functions can be set through programming, depending on the type of installation.

TECHNICAL SPECIFICATIONS

Power supply	230V
No. of motors	1 o 2 motors
Motor power supply	230V
Maximum motor power	0,5 Hp max
Accessory power supply	24 Vac 8W max
Automatic closing time	max 240 sec
Storable transmitters	200 max
Transmitter type	Rolling-code 433MHz
Flasher	230V 40W max
Electric lock	12/24V
Electric lock	230V
F1	350 mA
F2	5A
Operating temperature	-20 / +55 °C



WARNING

Before carrying out any type of intervention, ensure that the main power supply has been disconnected and always work safely. Operations involving the risk of contact with electricity must always be carried out by appropriately trained technical personnel.

GENERAL OUTLINE

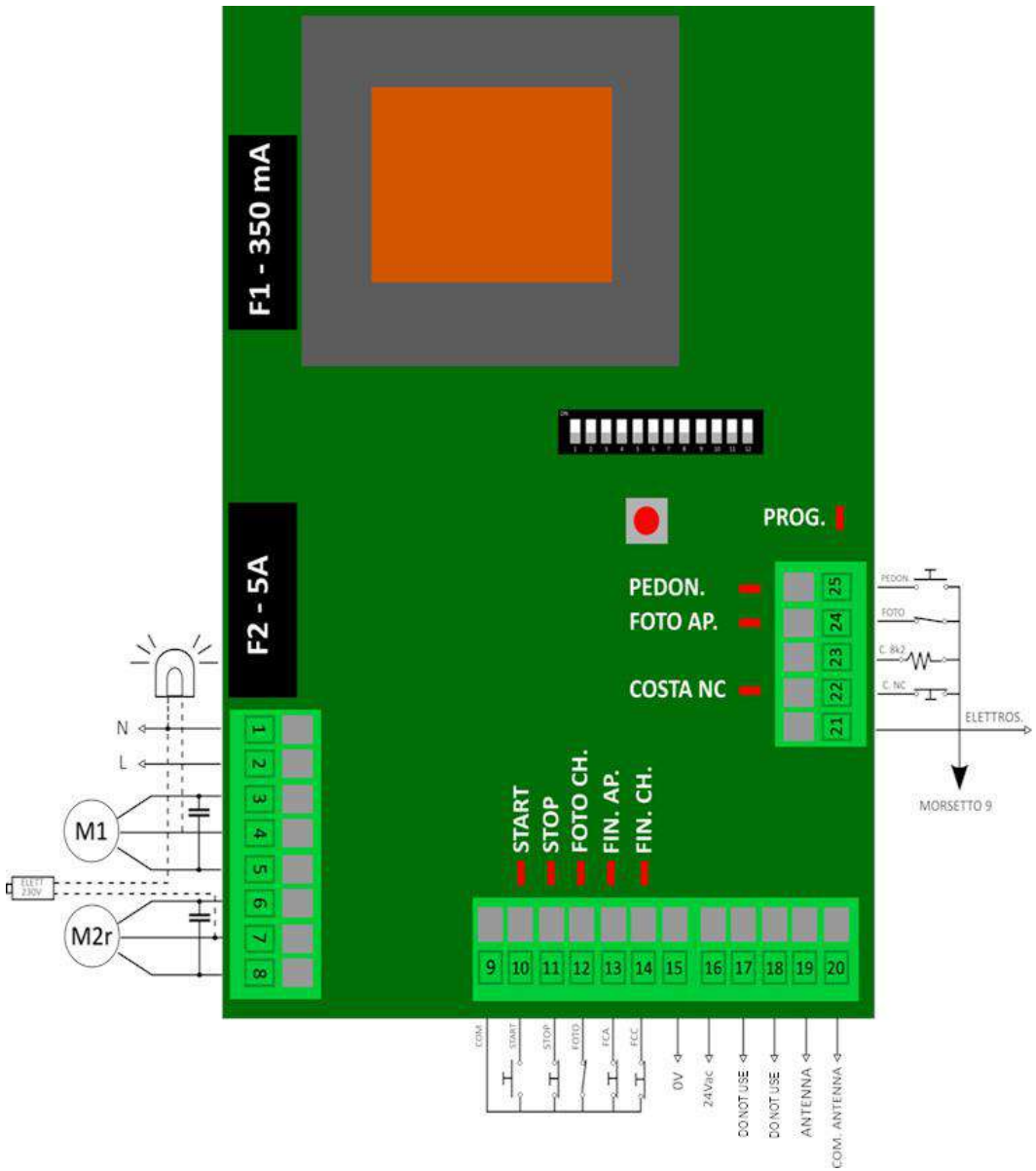

MOTOR CONNECTIONS and FLASHING LIGHT

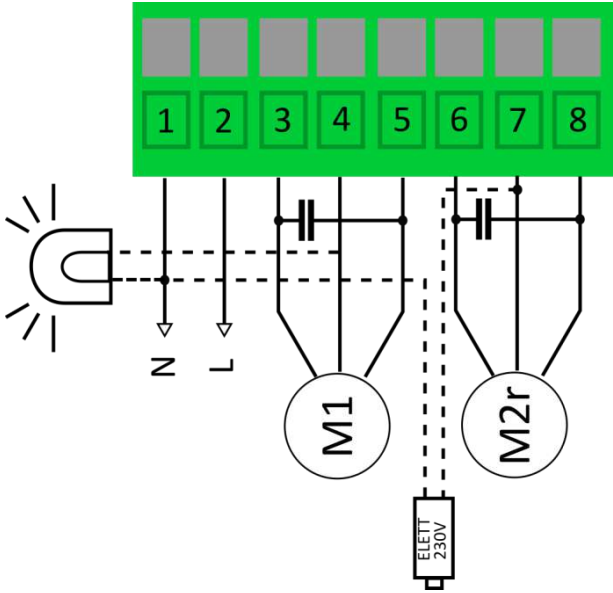

OPENING AND STOP INPUT CONNECTIONS

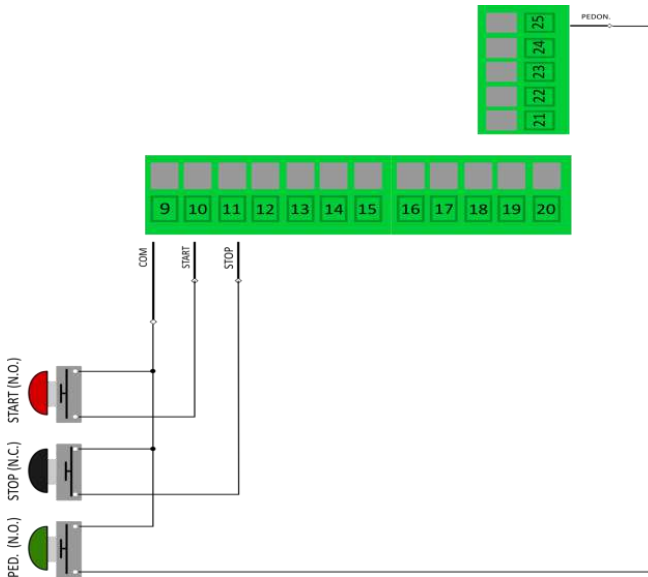

SECURITY CONNECTION

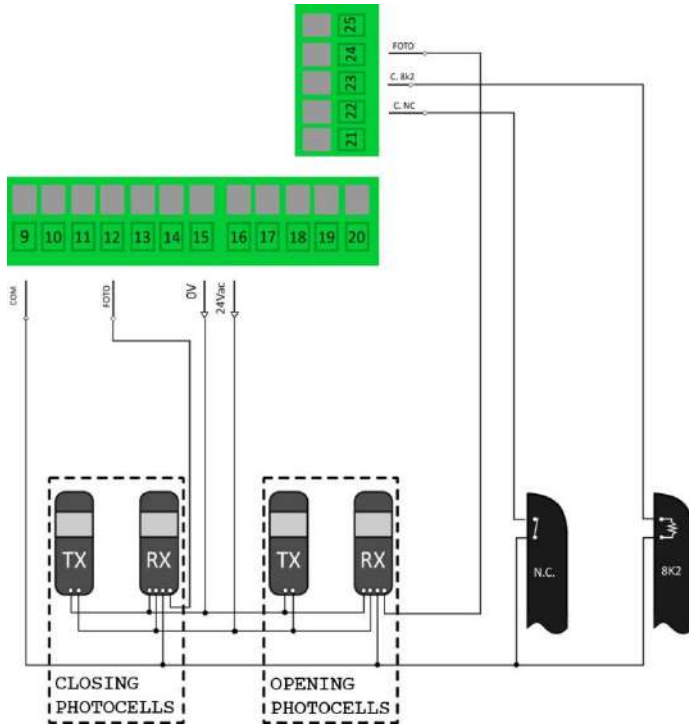

COLLEGAMENTO ELETTROSERRATURA

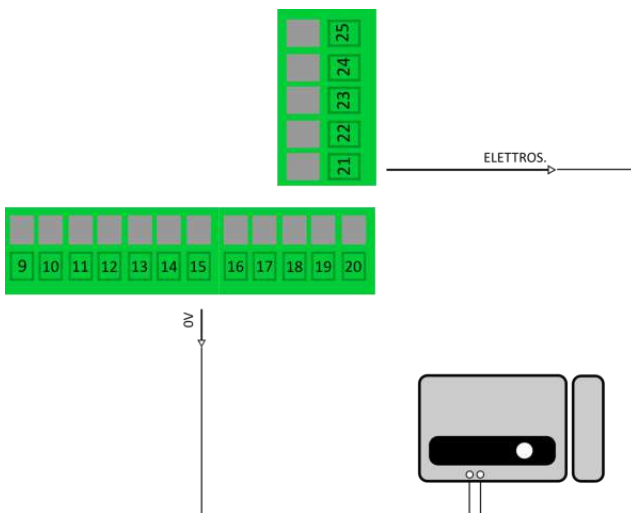

CONNECTIONS DESCRIPTION

1	Power supply (Neutral)	13	Open limit switch
2	Power supply (Phase)	14	Close limit switch
3	Motor 1 - Open	15	0V – Power supply/Electro-lock
4	Motor 1 Common	16	24V – Accessory power supply
5	Motor 1 Close	17	DO NOT USE
6	Motor 2 - Open	18	DO NOT USE
7	Motor 2 - Common	19	Antenna (central)
8	Motor 2 - Close	20	Antenna (gauze)
9	Common security devices and controls	21	Electric lock 12/24V
10	<p>Start</p> <p>An NO type TIMER contact can also be connected to terminals 10 and 9.</p> <p>When the input closes, and for as long as it remains in this state, the gate will remain open.</p> <p>When the contact opens, normal operation is restored.</p>	22	<p>Costa N.C.</p> <p>Reverses movement for 3 seconds to release the obstacle.</p>
11	Stop	23	<p>Costa 8K2</p> <p>Reverses movement for 3 seconds to release the obstacle.</p>
12	<p>Closing photocells.</p> <p>During the closing process, it stops the movement and reopens immediately.</p> <p>Irrelevant during opening.</p>	24	<p>Opening photocells.</p> <p>During the opening process, it stops moving and when it is free, it continues to open.</p> <p>With CONDOMINIUM LOGIC, during the pause, it recharges the time.</p> <p>During the closing process, it stops moving and when it is free, it reopens.</p>
		25	Pedestrian start.

INDICATOR AND DIAGNOSTIC LEDS

START	Lights up when it receives a START signal from the terminal block
STOP	Lights up when the STOP input is closed
FOTO CH.	Lights up when the FOT CH. input is closed
FIN. AP.	Lights up when the FIN. AP. input is closed or excluded
FIN. CH.	Lights up when the FIN.CH. input is closed or excluded
COSTA NC	Lights up when the COSTA NC. input is closed or excluded
FOTO AP.	Lights up when the FOTO AP. input is closed or excluded
PEDONALE	Lights up when it receives a PEDESTRIAN START signal from the terminal block
PROG.	LED provides various information.

DIP SWITCHES SEQUENCE

	Default settings highlighted in grey
--	--------------------------------------

Dip	Function	Status	Description
1	PROGRAMMING	ON	Enable time scheduling
		OFF	Normal operation
2 3	LOGIC OPERATION	OFF OFF	4-STEP PLUS LOGIC A START after opening stops the automation, if there is not another START after the pause time, it closes again. A STOP during closing stops the automation until the next impulse. Automatic closing time enabled. SAFETY CLOSE* function activated.
		ON OFF	STEP-BY-STEP LOGIC The pause time is disabled, so each time the START pulse is activated, the gate will open, then lock at the next pulse. The same operation applies during closing.
		OFF ON	CONDOMINIUM LOGIC With this logic, after the first START impulse, the automation will not accept any other signals. During the pause, a START signal will recharge the time. During the closing manoeuvre, the automation will reopen after a START signal. Pause time enabled.
		ON ON	4-STEP LOGIC With this logic, during the opening and closing manoeuvres, the gate will lock and remain in that position until the next START.
4	FOTO AP.	ON	Input [24] PHOTO AP. disabled
		OFF	Input [24] PHOTO AP. enabled
5	WATER HAMMER	ON	Enables the 12/24V electric lock water hammer. At the end of closing, maximum power to the motors for 2 seconds.
		OFF	Disables water hammer.
6	SLOWDOWNS	ON	Enable slowdowns during closing and opening. Do not use this function with hydraulic motors.
		OFF	Disable slowdowns.
7	STOP	ON	Input [11] STOP disabled
		OFF	Input [11] STOP enabled

8	HABILITATION HYDRAULIC MOTORS/ SLOWING DOWN HABILITATION	ON	Enables functions suitable for hydraulic motors: - Maximum power - Hydraulic seal: every 180 minutes, the control unit sends a closing signal of approximately 2 seconds to restore pressure in the hydraulic operators. - Low deceleration speed
		OFF	Disables hydraulic functions. High deceleration speed.
9	FCA	ON	Input [13] FCA disabled
		OFF	Input [13] FCA enabled
10	FCC	ON	Input [14] FCC disabled
		OFF	Input [14] FCC enabled
11	COSTA NC	ON	Input [22] COSTA NC disabled
		OFF	Input [22] COSTA NC enabled
12	COSTA 8K2	ON	Input [23] COSTA 8K2 disabled
		OFF	Input [23] COSTA 8K2 enabled

* The SAFETY CLOSE function automatically closes the gate if the power supply fails during opening or closing or during a pause. When power is restored, the control unit will perform a complete closing manoeuvre.

TRANSMITTER PROGRAMMING

Before programming transmitters, make sure that all safety inputs are closed.

The receiver accepts 433 MHz both radio controls, fixed code and rolling code types. The first transmitter will set the receiver to one of the two types of operation. Resetting the memory will restore the receiver to its factory settings, and the type of operation can be set again.

START PROGRAMMING

To programme a button on the remote control with the START function, proceed as follows:

1. Press the P1 button for one second.
2. The PROG. LED will light up steadily.
3. Now press and hold the button on the remote control that you want to memorise.

4. The PROG. LED will start flashing to confirm that it has been memorised correctly.
5. Release the transmitter button.

As long as the LED stays lighted, you can program other remote controls starting from step 3.

Once finished, wait about 6 seconds to exit programming mode and return to normal operation.

PEDESTRIAN PROGRAMMING



ATTENTION



The pedestrian button programming can only be performed if at least one transmitter has already been programmed as START.

To programme a button as a pedestrian opening, proceed as follows:

1. Press the P1 button twice (each press must hold for 1 second)
2. The PROG LED will flash in a special pattern, consisting of two flashes followed by a pause.
3. Now press and hold the button on the remote control that you wish to memorise.
4. The PROG LED flashes to confirm that the memory has been saved correctly.
5. Release the transmitter button.

As long as the LED continues to flash, you can programme other remote controls starting from step 3.

Once completed, wait approximately 6 seconds to exit programming mode and return to normal operation

TOTAL RADIO MEMORY DELETION

To delete the radio memory and restore the factory settings in the integrated receiver, press and hold the P1 button.

The PROG LED will light up steadily. When it turns off, you can release the P1 button; the deletion has been successful.

TIMING SCHEDULE



ATTENTION



If deceleration and/or water hammer are used, the timing must be programmed with these included. They cannot be added later.

Before starting the time-learning process, you must check:

1. The gate must be closed and the motors locked.
2. There must be no transit in front of the photocells during programming manoeuvres.
3. Connect the door that opens first to output M2 terminals [6-7-8] and the door that opens next M1 to terminals [3-4-5].
4. A transmitter must have been registered.









After completing the preliminary checks described above, you can proceed with learning time.



The following procedure sets the motor operating times, the opening phase shift time, the closing phase shift time and the pause time (even if this is disabled, it must be set).

2-DOOR GATE





HYDRAULIC MOTORS (disable slowdowns DIP 6 in OFF)







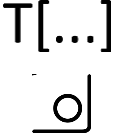

	Set DIP switch 1 to the ON position.
	Press the START button on the transmitter or use a button previously connected to inputs [9 – 10].
	The M2 door connected to terminals [6-7-8] must start opening (if it doesn't, reverse wires [6-8], disconnect the power supply, and start the procedure again).
	Once the selected delay time between the doors has elapsed, press START again.

	<p>The M1 door connected to terminals [3-4-5] must start opening (if it doesn't work, reverse the wires [3-5], disconnect the power supply, and start the procedure again).</p>
	<p>When M2 door , which opened first, reaches the stop, wait about 5/7 seconds and then press START again to lock it.</p>
	<p>When M1 door, which opened second, reaches the stop, wait 5/7 seconds and then press START again to lock it.</p>
<p>T[...]</p> 	<p>Wait for the time you want to set as the pause time and press START again.</p>
	<p>The M1 door will restart on closure.</p>
<p>T[...]</p> 	<p>Once the selected closing delay time between the doors has elapsed, press START again.</p>
	<p>The M2 door will restart on closure.</p>
	<p>When the M1 door that closed first reaches the closing stop, wait 5/7 seconds and then press START again to lock it.</p>
	<p>When the M2 door, which closed second, reaches the closing stop, wait 5-7 seconds and then press START again to lock it.</p>

	<p>The PROGR LED starts flashing to indicate the end of the programming phase.</p>
	<p>Return DIP 1 to the OFF position.</p>

ELECTRO-MECHANICAL MOTORS

	<p>Set DIP switch 1 to the ON position.</p>
	<p>Press START button on the transmitter or use a button previously connected to inputs [9 – 10].</p>
	<p>The M2 door connected to terminals [6-7-8] must start opening (if this is not the case, reverse the wires [6-8], disconnect the power supply and restart the procedure.</p>
	<p>Once the desired opening delay time between the doors has elapsed, press START again.</p>
	<p>The M1 door connected to terminals [3-4-5] must start opening (if this is not the case, reverse wires [3-5], disconnect the power supply and restart the procedure.</p>
	<p>When the M2 door, which opened first, reaches the stop, press START again to lock it. If electric limit switches are present, skip this step.</p>







	<p>When the M1 door, which opened second, reaches the stop, press START again to lock it. If electric limit switches are present, skip this step.</p>
<p>T[...]</p> 	<p>Now wait for the time you want to set as the pause time and press START again.</p>
	<p>The M1 door will restart on closing.</p>
<p>T[...]</p> 	<p>Once the closing delay time set between the doors has elapsed, press START again.</p>
	<p>The M2 door will restart on closing.</p>
	<p>When the M1 door, that closed first, reaches the closing stop, press START again to lock it. If electric limit switches are present, skip this step.</p>
	<p>When the M2 door, which closed second, reaches the closing stop, press START again to lock it. If electric limit switches are present, skip this step.</p>
	<p>The PROGR LED flashes to indicate that the programming phase is complete.</p>
	<p>Return DIP 1 to the OFF position.</p>



If the decelerations were set in the regular manoeuvre, there will be a slowdown based on the times set in the programming.

PEDESTRIAN ACCESS

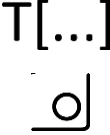





The pedestrian door is the one connected to terminals [6-7-8], then M2.
Before proceeding, ensure that at least one transmitter has been registered with the pedestrian button. This will be used for programming times.



OLEODYNAMIC MOTORS (disable slowdowns DIP 6 in OFF)

	Set DIP switch 1 to the ON position.
	Press the PEDESTRIAN START button on the transmitter.
	The M2 door connected to terminals [6-7-8] must start opening (if this is not the case, reverse wires [6-8], disconnect the power supply and restart the procedure.
	When the M2 door reaches the stop, wait 5-7 seconds and then press PEDESTRIAN START again to lock it. If electric limit switches are present, skip this step.
	Now wait for the time you wish to set as the automatic closing time and press PEDESTRIAN START again.
	The M2 door will restart on closing.
	When the M2 door reaches the closing stop, wait 5-7 seconds and then press PEDESTRIAN START again to lock it. If electric limit switches are present, skip this step.

	<p>The PROGR. LED flashes to indicate that the programming phase is complete.</p>
	<p>Return DIP 1 to the OFF position.</p>

ELECTRO-MECHANICAL MOTOR







	<p>Set DIP switch 1 to the ON position.</p>
	<p>Press the PEDESTRIAN START button on the transmitter.</p>
	<p>The M2 door connected to terminals [6-7-8] must start to open. If this does not happen, reverse the wires [6-8], disconnect the power supply and restart the procedure.</p>
	<p>When the M2 door reaches the stop, press PEDESTRIAN START again to lock it. If electric limit switches are present, skip this step.</p>
<p>T[...]</p> 	<p>Now wait for the time to be set as the "pause time" and press PEDESTRIAN START again.</p>
	<p>Door M2 will restart on closing.</p>
	<p>When the M2 door reaches the closing stop, press PEDESTRIAN START again to lock it. If electric limit switches are present, skip this step.</p>



	<p>The PROGR LED flashes to indicate that the programming phase is complete.</p>
	<p>Return DIP 1 to the OFF position.</p>

ONE-DOOR SITUATION







In this situation the single motor connection must be made on terminals [6-7-8], therefore M2.



OLEODYNAMIC MOTORS (disable slowdowns DIP 6 in OFF)

	<p>Switch DIP 1 to ON position.</p>
	<p>Press the P1 button on the card.</p>
	<p>The M2 door connected to terminals [6-7-8] must start to open. If this does not happen, reverse the wires [6-8], disconnect the power supply and restart the procedure.</p>
	<p>When the M2 door reaches the stop, wait 5/7 seconds and then press START again to lock it. If electric limit switches are present, skip this step.</p>
<p>T[...]</p> 	<p>Waiting for the time to be set as the automatic closing time and press START again.</p>
	<p>The M2 door will restart on closing.</p>

	<p>When the M2 door reaches the closing stop, wait 5/7 seconds and then press START again to lock it. If electric limit switches are present, skip this step.</p>
	<p>The PROGR LED flashes to indicate the end of the programming phase.</p>
	<p>Return DIP 1 to the OFF position.</p>

ELECTRO-MECHANICAL MOTOR

	<p>Turn DIP switch 1 to the ON position.</p>
	<p>Press the P1 button on the board.</p>
	<p>The M2 door connected to terminals [6-7-8] must start opening (if this is not the case, reverse the wires [6-8], disconnect the power supply and restart the procedure).</p>
	<p>When the M2 door reaches the stop, press START again to lock it. If electric limit switches are present, skip this step.</p>
<p>T[...]</p> 	<p>Waiting for the time to be set as the automatic closing time and press START again.</p>
	<p>The M2 door will restart on closing.</p>

	<p>When the M2 door reaches the closing stop, press START again to lock it. If electric limit switches are present, skip this step.</p>
	<p>The PROGR LED flashes to indicate the end of the programming phase.</p>
	<p>Return DIP 1 to the OFF position.</p>

If the decelerations were set in the regular manoeuvre, there will be a slowdown based on the times set in the programming.

MOTOR TORQUE ADJUSTMENT (only with DIP 8 OFF)

The motor torque is set to maximum at the manufacturer's standard settings. This setting in oleodynamic motors must not be modified, as in this type of operator the force adjustment is on board and lower forces, set electronically, could cause abnormal operation.

During normal door movement, pressing button P1 decreases the force by a maximum of 6 levels. The seventh time it is pressed, the force returns to maximum and the cycle restarts.

Pressed	Force
1	95% of maximum force
2	90% of maximum force
3	80% of maximum force
4	70% of maximum force
5	50% of maximum force
6	40% of maximum force
7	100% Maximum force
[...]	Restart cycle

At the first power supply, the PROG LED flashes a number of times equal to the strength setting.

FAST CLOSING FUNCTION

This function reduces the pause time to 3 seconds after the photocells have been cleared. To activate this function, during time programming, with the gate paused in the open position, activate the photocells for 2 seconds. The PORG LED will flash. The function is enabled.

To disable, follow the same procedure.

Prodotto italiano – made in Italy – vers. 3/23

